



PROFESSIONAL LIFTING EQUIPMENT

MODELS 78099 ENGINE SUPPORT TOOL SETUP • OPERATING INSTRUCTIONS

Note: Revision letters (A,B,C,D ect.) after model numbers have been omitted as they do not affect the setup, operating and maintenance instructions of a particular product unless otherwise noted.

The engine support tool is designed to handle 4, 6 and 8 cylinder automobile engines.
Become familiar with the description and purpose of each component.

⚠ WARNING

- NEVER USE THE NORCO MODEL 78099 ENGINE SUPPORT TOOL AND/OR ITS COMPONENTS FOR LIFTING PURPOSES. THEY ARE STRICTLY DESIGNED TO TEMPORARILY SUPPORT AN ENGINE IN PLACE BEFORE THE ENGINE MOUNTING BOLTS ARE REMOVED. THE CONDITION OF THE NORCO ENGINE SUPPORT TOOL, CHAIN OR WIRE ROPE MUST BE INSPECTED BEFORE EVERY JOB. ANY COMPONENTS SHOWING SIGNS OF FATIGUE, STRESS FRACTURES OR UNUSUAL WEAR SHOULD BE IMMEDIATELY REPAIRED OR REPLACED.
- NORCO CANNOT BE RESPONSIBLE FOR PRODUCT DAMAGE, PERSONAL INJURY AND/OR PROPERTY DAMAGE DUE TO FAULTY JUDGEMENT OR IMPROPER USE OF TOOLS BECAUSE:
 - a. Engines have different centers of balance from one automotive manufacturer to another.
 - b. Operator's shop equipment used in conjunction with the Norco Engine Support Tool may not be adequate or safe.
 - c. The versatility of this tool is limited only by the ingenuity of its operators. Use this tool only for its intended purpose.

INDEX NO.	DESCRIPTION	PART NO.	REQ'D NO.
1	Main Transverse Support Bar	940090	1
2	Strut Tower Mount	940095	2
3	Positioning Bracket	940091	8
4	Plastic Knob	940092	2
5	Metal Knob	940093	3
6	Front Support Adapter	940100	2
7	Screw Pad Housing Assembly	45101079	2
8	Screw Pad Assembly	940110	2
9	Rubber Cover	940094	2
10	Adjustment Hook	940096	3
11	Bearing	940097	3
12	Washer	940098	6
13	Long Bolt	940101	2
14	Short Bolt	940102	2
15	Nut	940103	4
16	Threaded Positioning Bracket	45101081	2
17	End Cap	940106	12

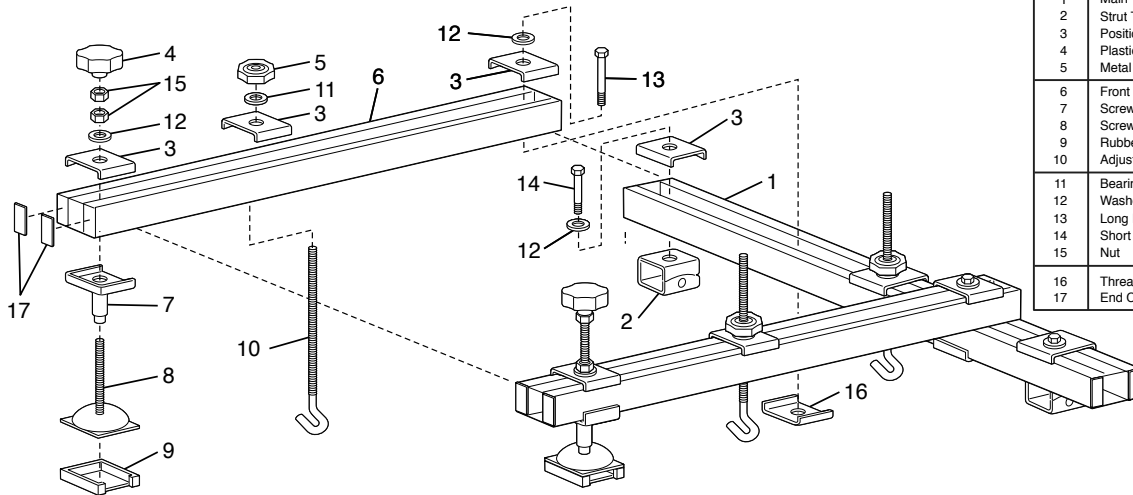

SETUP

1. The main transverse support bar (1) can be adapted to most vehicles by sliding the fully adjustable strut tower mounts (2) on the support bar and over the strut towers. The strut tower mounts must be pivoted fore and aft and/or side to side to match the strut tower's mounting surfaces. Secure the strut tower mounts to the transverse support bar by tightening the bolts (14).

2. Heavier or unusual configured engines might require the use of one or two front support adapters (6). Front support adapters are attached to the main transverse support bar and the opposite ends of the adapters are supported by the adjustable screw pads (8). The screw pads must have a firm foundation to rest on like a vehicle frame or subframe that can withstand the weight of the engine. Most engines include handling tabs that are positioned where engine weight is balanced. Front support adapters must be positioned in relation to the engine handling tabs to achieve proper weight balance and distribution. Once the front support adapters are properly positioned, tighten them to the main transverse support bar.

3. Depending on the engine configuration and the location on the engine handling tabs, position the adjustment hooks (10) on the main transverse support bar and/or the front support adapter(s) at the engine handling tab locations.

4. A chain or wire rope capable of handling more than the weight of the engine should be attached to the engine handling tabs at one end and the adjustable hooks at the other end. The majority of the chain or the wire rope slack should be taken up upon initial connection. Final tightening of the chain or wire rope can be accomplished by turning the spin knobs (5) on the adjustment hooks in a clockwise direction.

WARNING: THE SHOP CRANE OR LIFTING MECHANISM THAT MOVES THE ENGINE INTO DESIRED POSITION CANNOT BE DISCONNECTED FROM THE ENGINE UNTIL THE OPERATOR IS SURE THE ENGINE SUPPORT TOOL SETUP IS STABLE, SECURE AND SAFE.