



---

## MODEL 78035 PRESS GUARD FOR 25 TON PRESS SETUP & OPERATING INSTRUCTIONS

Note: Revision letters (A, B, C, D etc.) after model numbers have been omitted as they do not affect the setup, operating and maintenance instructions of a particular jack unless otherwise noted.

---

### **IMPORTANT: READ THESE INSTRUCTIONS BEFORE OPERATING**

**BEFORE USING THIS PRESS, READ THIS MANUAL COMPLETELY AND THOROUGHLY, UNDERSTAND ITS OPERATING PROCEDURES, SAFETY WARNINGS AND MAINTENANCE REQUIREMENTS. FAILURE TO DO SO COULD CAUSE ACCIDENTS RESULTING IN SERIOUS OR FATAL PERSONAL INJURY AND/OR PROPERTY DAMAGE.**

The use of hydraulic shop presses is subject to certain hazards that cannot be prevented by mechanical means, but only by the exercise of intelligence, care, and common sense. It is therefore essential to have owners and personnel involved in the use and operation of equipment who are careful, competent, trained, and qualified in the safe operation of the equipment and its proper use. Examples of hazards are part breakage resulting in flying parts, slipping and dropping of components to be pressed caused primarily by not using guards or protective blankets over

the components, improperly securing adjustments on the press, improperly securing components to be pressed, overloading and off-center loads.

It is the responsibility of the owner to make sure all personnel read this manual prior to using this device. It is also the responsibility of the device owner to keep this manual intact and in a convenient location for all to see and read. If the manual is lost or not legible, contact Norco Industries, Inc. for a free replacement. If the operator is not fluent in English, the product and safety instructions shall be read to and discussed with the operator in the operator's native language by the purchaser/ owner or his designee, making sure that the operator comprehends its contents.

#### **WARRANTY**

This press is covered by a Limited Lifetime Warranty. For details see the back cover of Norco's product catalog.

---

### **FINISHED INSTALLATION**

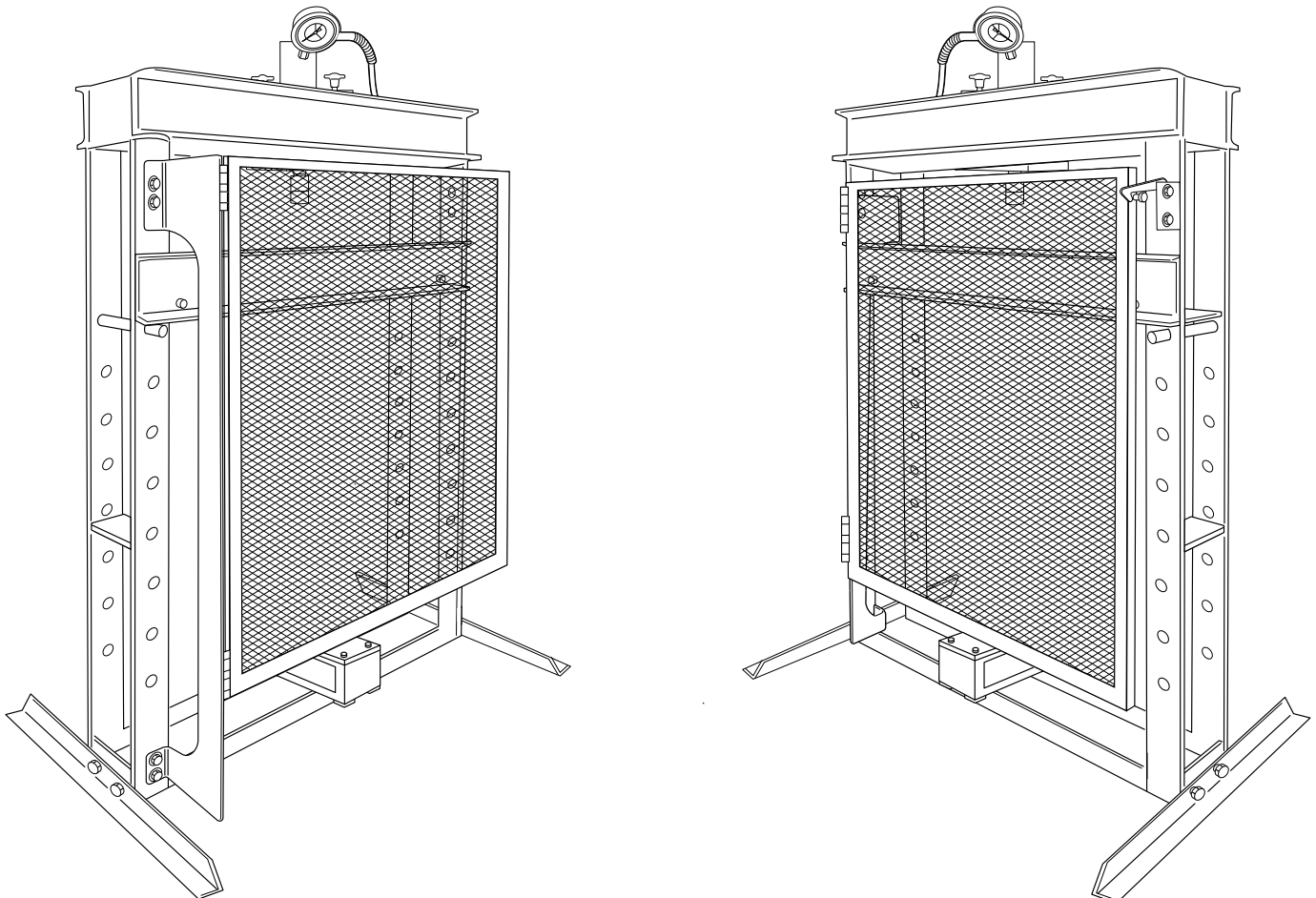

## SETUP INSTRUCTIONS

1. Position guard and clamp into place so guard can be opened or closed. Make sure maximum protection is provided to press operator. Also make sure guard opens and closes properly.
2. **(A)** Make sure latch and latch mount are positioned so latch catches pin on guard and that latch stays engaged. **(B)** Mark location for latch mount and clamp into place.

3. Drill holes for press guard and bolt into place.
4. Drill holes for latch mount.
5. Install guard and latch assembly with hardware provided.

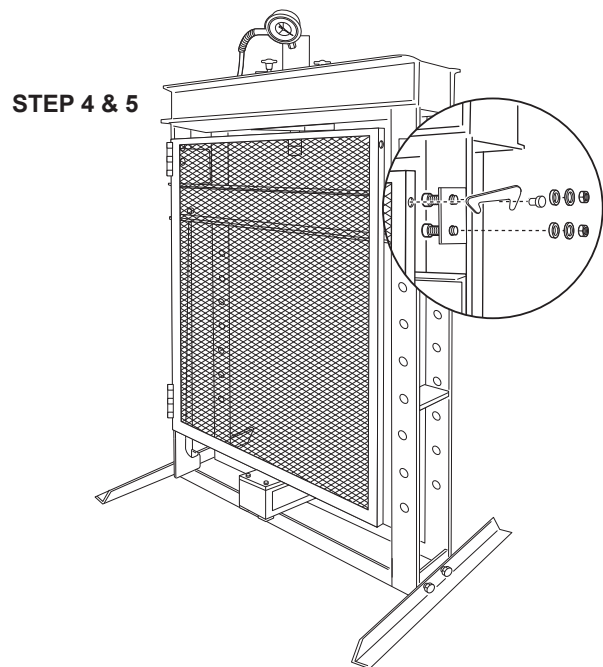
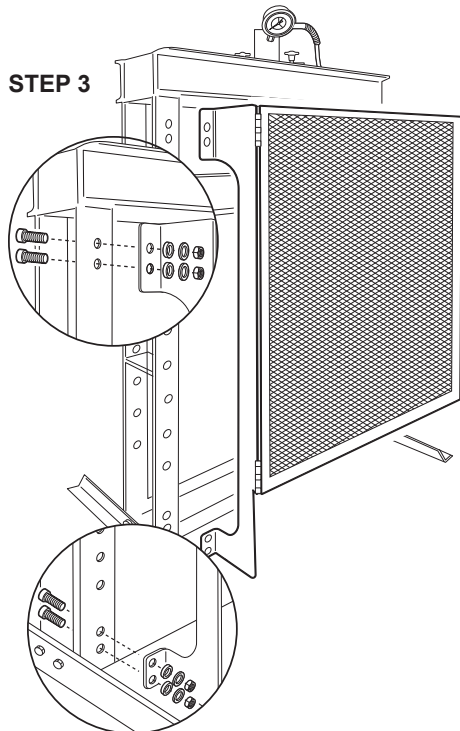
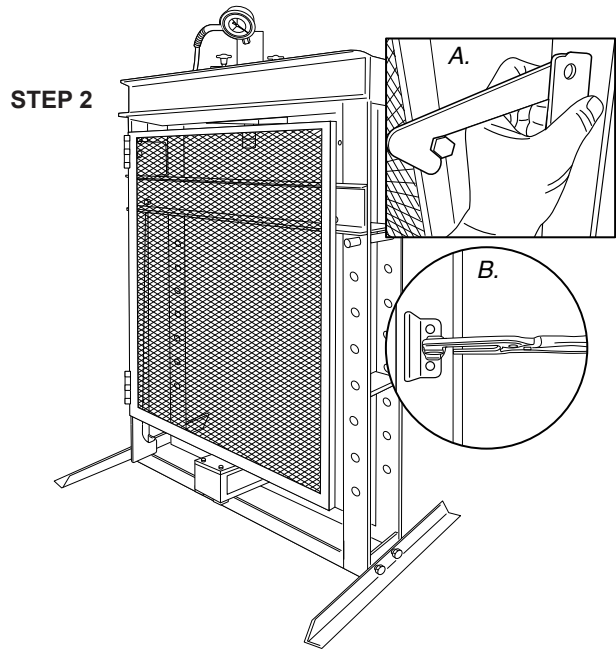
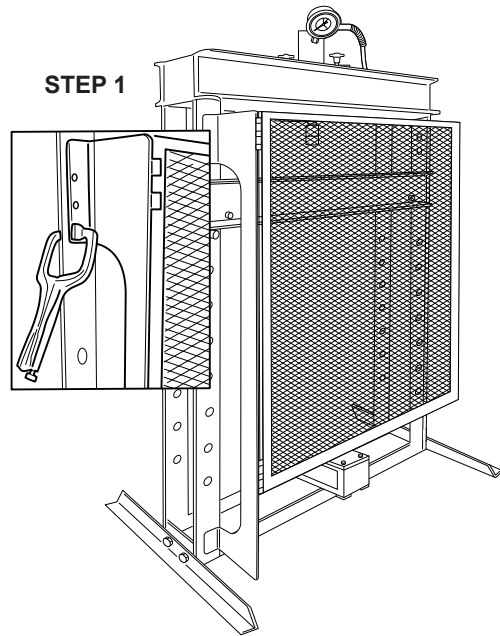

## REPAIR SERVICE

If your Norco product requires service or repair, contact the Norco Customer Service Department for the location of the nearest Norco Authorized Service Center.

Norco Industries, Inc.  
365 West Victoria St.  
Compton, CA 90220  
(310) 639-4000 • Fax: (310) 639-7411  
[www.norcoindustries.com](http://www.norcoindustries.com)

It will be necessary to provide the Norco Authorized Service Center with a copy of the bill of sale if requesting warranty repair. If the authorized service center determines your product is eligible for warranty repair, the repair will be made at no charge and returned freight prepaid. The cost of non-warrantable service, repair, and return freight is the customer's responsibility.