

norco

DESCRIPTION
AIR/HYDRAULIC FLOOR JACK

CAPACITY
5 TON

MODEL NO.
71550A

REPLACEMENT
PARTS

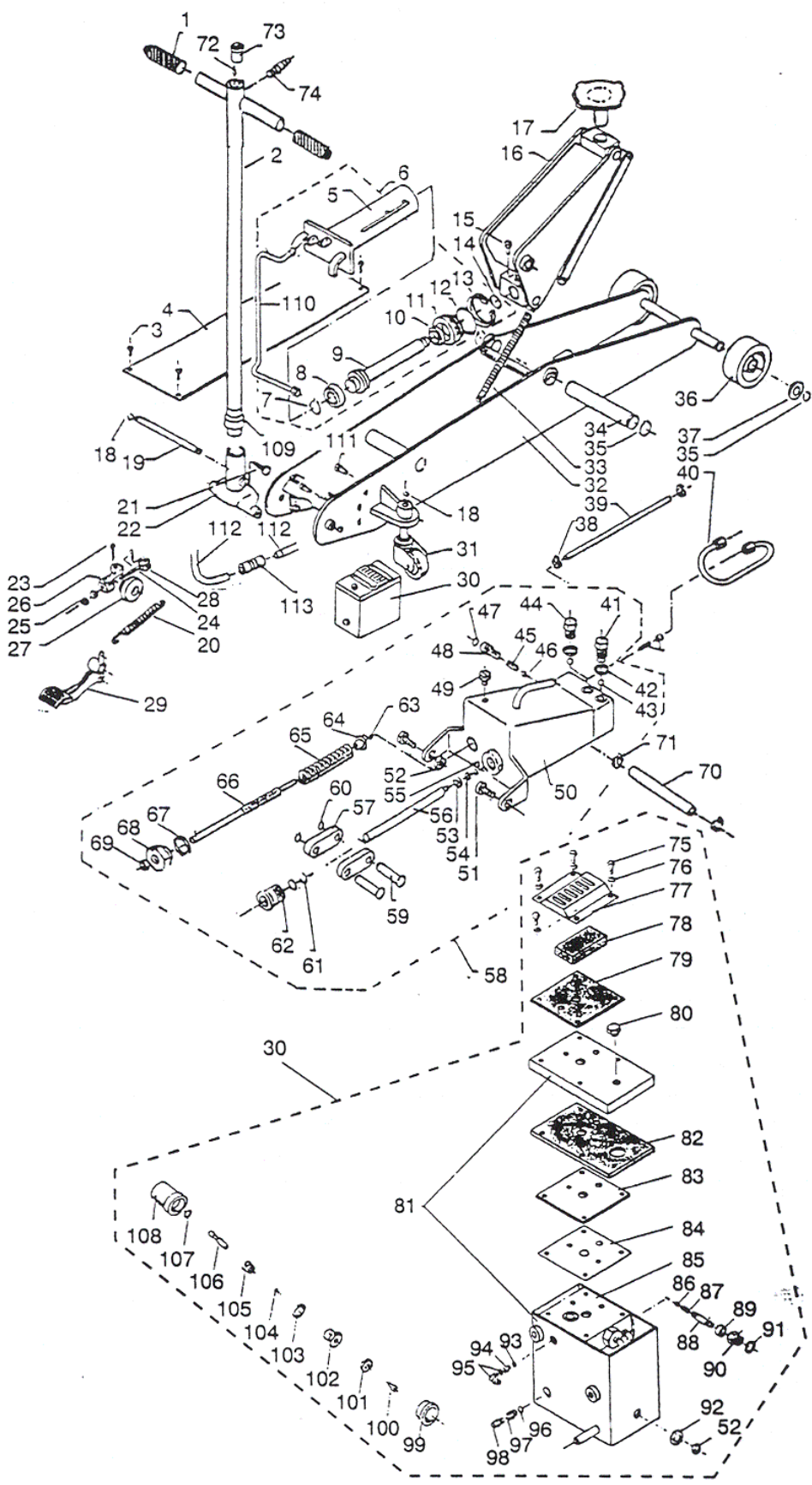

INDEX NO.	DESCRIPTION	PART NO.	QTY.
1	Handle grip	251113	2
2	Handle	255746	1
3	Cover screw	255639	4
4	Cover	255188	1
5	Cylinder	255747	1
6	Cylinder assy. complete	255745	1
7	Retaining ring	255025	1
*8	Ram u-cup	255026	1
9	Ram	255748	1
*10	Oil seal	255058	1
11	Cylinder bearing	255710	1
*12	O-ring	255707	1
13	Retaining ring	255708	1
*14	O-ring	255496	1
15	Screw	255214	1
16	Elevator arm assy.	255176	1
17	Lifting saddle	255163	1
18	Retainining ring	255135	4
19	Shaft	255636	1
20	Extension spring	255749	1
21	Handle base screw	255122	1
22	Handle base	255123	1
23	Cotter pin	255132	1
24	Cotter pin	255206	1
25	Nut	255128	2
26	Release arm	255131	1
27	Release hub	255130	1
28	Release lever	255127	1
29	Pump pedal	255751	1
30	Air pump assy. complete	225750	1
31	Caster assy.	255177	2
32	Chassis	255752	1
33	Spring	255162	1
34	Elevator arm shaft	255186	1
35	Retaining ring	255175	2
36	Front wheel	255164	2
37	Flat washer	255168	2
38	Hose clamp	255497	2

INDEX NO.	DESCRIPTION	PART NO.	QTY.
39	Hose	255495	1
40	Tube assy.	255498	1
41	Cover screw (intake)	255017	1
*42	Copper gasket	255018	2
*43	Checkball .312 diameter	9005	2
44	Cover screw (discharge)	255020	1
45	Overload spring	255525	1
*46	Checkball, .250 diameter	9004	1
*47	O-ring	255523	1
48	Cover screw (overload)	255524	1
*49	Reservoir fill plug	255015	1
50	Oil block	255753	1
51	Mounting bolt	255166	2
52	Mounting nut	255167	2
*53	Pump piston u-cup	255136	1
*54	Brass retainer washer	255137	1
55	Retaining ring	255138	1
56	Pump piston	255139	1
57	Connecting rod (steel)	255141	2
58	Hydraulic block assy. complete	255755	1
59	Rivet pins	255144	2
60	Retaining ring	255120	4
*61	O-ring	255142	2
*62	Pump bearing (brass)	255143	1
*63	Checkball, .156 diameter	9021	1
64	Spring guide	255116	1
65	Release spring	225115	1
66	Release shaft	255114	1
*67	Gasket	255113	1
68	Release guide bushing	255112	1
*69	Release oil seal	255111	1
70	Oil hose	255756	1
71	Hose clamp	255757	2
72	Connector	255758	1
73	Air valve	255759	1
74	Male air coupler	255761	1
75	Screw	255762	4

INDEX NO.	DESCRIPTION	PART NO.	QTY.
76	Washer	255763	4
77	Silencer cover	255764	1
78	Silencer	255766	1
79	Rubber gasket	255767	1
80	Oil plug	255768	1
81	Oil tank	255769	1
82	Rubber gasket	255771	1
83	Steel plate	255772	1
84	Cover gasket	255773	1
85	Pump mount	255774	1
86	Valve cone	255776	1
87	Spring	255777	1
88	Spindle	255778	1
89	Ring	255779	1
90	Nipple	255781	1
*91	Copper ring	255782	1
92	Nut	255783	1
*93	Copper ring	255784	1
94	Nipple	255786	1
95	Fitting	255787	1
*96	Copper ring	255788	1
97	Nipple	255789	1
98	Fitting	255791	1
99	Nylon sleeve	255792	1
100	Screw	255793	1
101	Washer	255794	1
102	Nut	255796	1
*103	Copper ring	255797	1
*104	O-ring	255798	1
105	Guide	255799	1
106	Support shaft	255801	1
*107	O-ring	255802	1
108	Valve housing	255803	1
109	Handle sleeve	255804	1
110	Pressure pipe	255806	1
111	Screw	255807	2
112	Set of hoses	255808	1
113	Double fitting	255809	1

* = designates those parts included in hydraulic repair kit part #205310
 * = designates those parts included in oil pump kit part #255810