



PROFESSIONAL LIFTING EQUIPMENT

## MODEL 78202 FORD 6.2L ENGINE ADAPTER

INDEX NO.	DESCRIPTION	PART NO.	REQ'D NO
1	Engine Adapter, MASTER	478374	1
2	Engine Adapter, SLAVE	478375	1
3	10mm Hex. Head Bolt	478371	8

### SETUP

1. Remove adapters from the shafts on the gear drive end and tail stock end of the Norco model 78200 engine stand. Keep the bolts and lockwashers handy as they will be used to secure this adapter to the shafts.

2. Secure the MASTER engine adapter P/N 478374 to the shaft on the tail stock end of the engine stand with the bolts and lockwashers provided. Secure the SLAVE engine adapter P/N 478375 to the shaft on the gear drive end of the engine stand with the bolts and lockwashers provided.

3. Adjust the base of the Norco model 78200 engine stand so that it is extended to its maximum length and secured with the screw knob provided.

### ADAPTER USE

1. Become familiar with the Operating Instructions that accompanies the Norco model 78200 engine stand and the vehicle manufacturer's instructions regarding all the requirements for proper removal and installation of FORD 6.2L engines.

2. Think in terms of adapting the engine stand with Norco model 78202 adapters to the engine, not the engine adapting to the stand. The engine must be removed from the vehicle and be properly and safely supported by a shop crane. Make sure the engine is just high enough above the floor where the engine stand with adapters does not have to be lifted more than 6" in order to secure the adapter flanges to the engine's mounting bosses.

3. Align the holes in either adapter with the corresponding engine mounting bosses and connect them by inserting the four metric bolts P/N 478371 provided. Finger tighten the bolts. Conduct the same procedure with the other adapter. It might be necessary to telescope the shaft on the tail stock end of the engine stand so the adapters properly cradle the engine mounting bosses. Tighten all eight metric bolts.

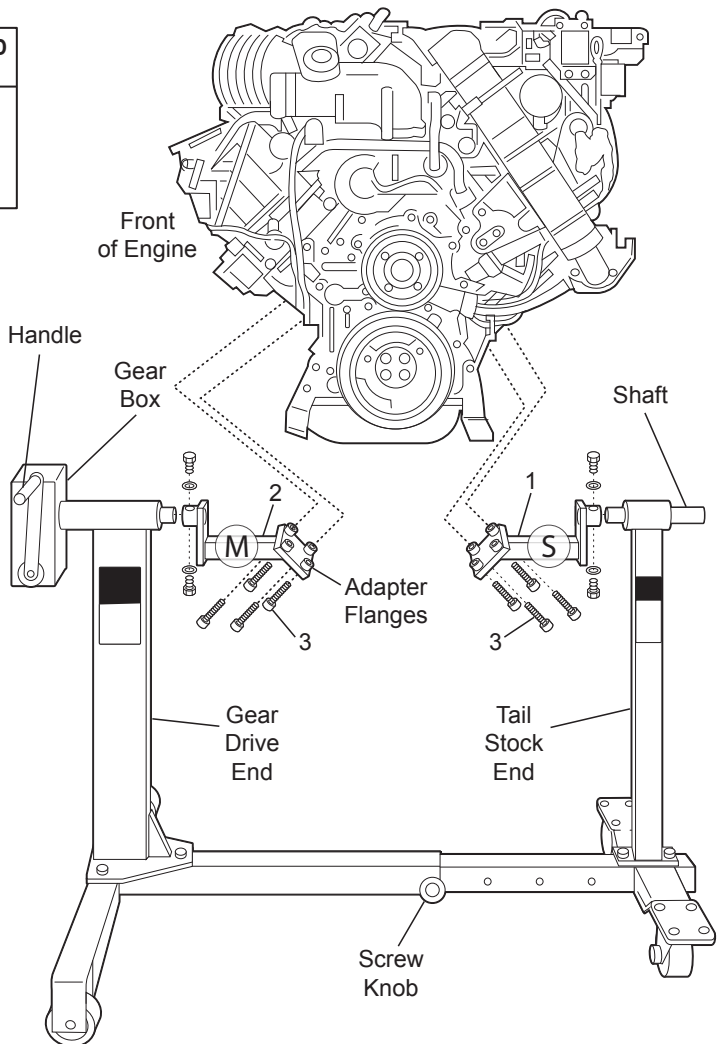

4. Lower the engine with engine stand attached very slowly to the ground so all four wheels of the engine stand are firmly planted on the ground before disconnecting the shop crane from the engine.

5. **IMPORTANT:** When rotating a fully dressed engine with the engine stand's gear box handle, rotate the handle slowly so the engine stand is not exposed to a shock load.